

# 40x40x10 mm

7.0~9.9 CFM



■ Specification

|  | Bearing | Rated Voltage | Power Current | Power Consumption | Speed | Airflow | Static Pressure         | Noise   | Weight | Curve |
|---|---------|---------------|---------------|-------------------|-------|---------|-------------------------|---------|--------|-------|
|   | ● VAPO  | (VDC)         | (mA)          | (WATTS)           | (RPM) | (CFM)   | (inch-H <sub>2</sub> O) | (dB(A)) | (g)    |       |
| MF40100V1-10000-A99   | ●       | 5             | 136           | 0.68              | 7000  | 8.0     | 0.19                    | 27.3    | 15.6   | 2     |
| MF40100V2-10000-A99   | ●       | 5             | 94            | 0.47              | 5800  | 7.0     | 0.12                    | 20.6    | 15.6   | 3     |
| MF40101VX-10000-A99   | ●       | 12            | 87            | 1.05              | 8500  | 9.9     | 0.25                    | 31.4    | 15.6   | 1     |
| MF40101V1-10000-A99   | ●       | 12            | 51            | 0.62              | 7000  | 8.0     | 0.19                    | 27.3    | 15.6   | 2     |
| MF40101V2-10000-A99   | ●       | 12            | 40            | 0.48              | 5800  | 7.0     | 0.12                    | 20.6    | 15.6   | 3     |

■ Function R Type : F99 / F Type : G99

■ Air Flow-Static Pressure Characteristics

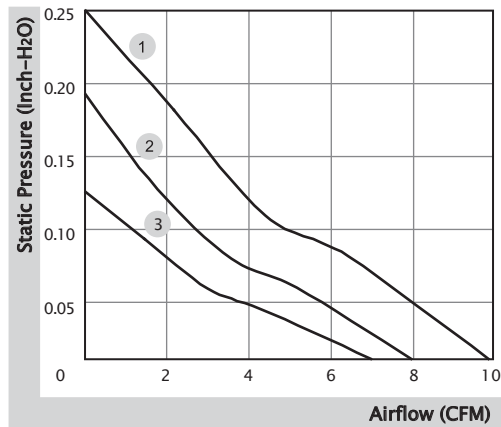

■ External Dimensions(mm)

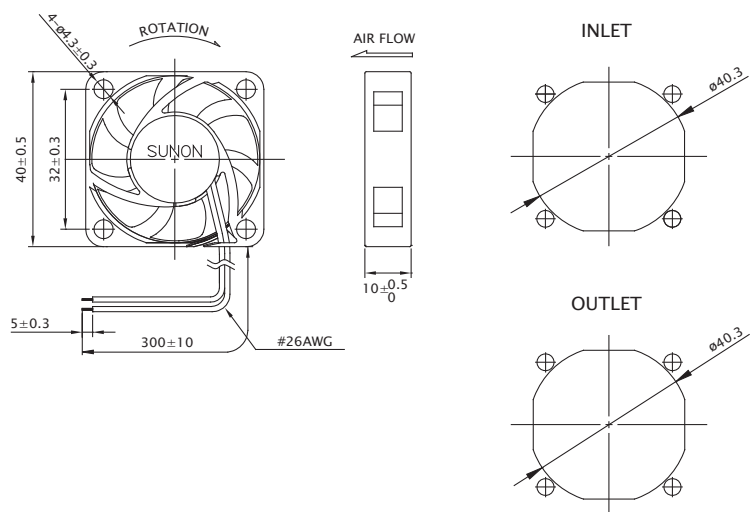

\* All model could be customized. Please contact with Sunon Sales.

\* Specifications are subject to change without notice. Please Visit SUNON website at [www.sunon.com](http://www.sunon.com) for update information.

■ RD / FG Output Signal

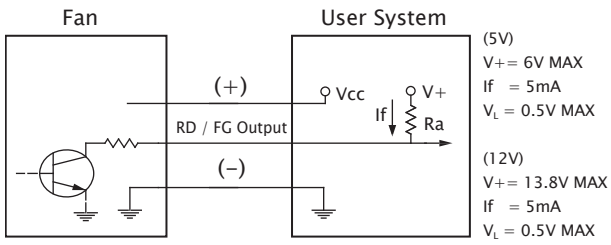

[ RD Signal ]

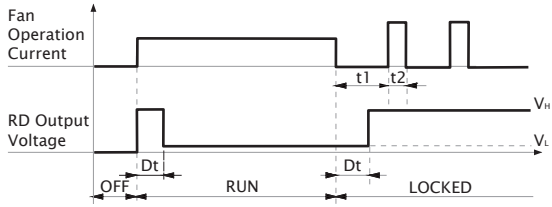

[ FG Signal ]

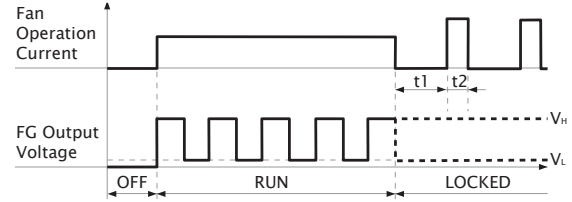
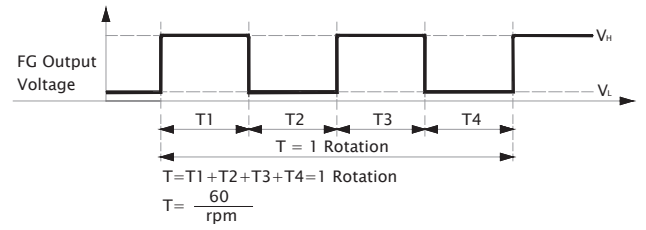

# 40x40x10 mm

5.5~10.0 CFM



■ Specification

| Model               | Bearing      | Rated Voltage | Power Current | Power Consumption | Speed | Airflow | Static Pressure         | Noise   | Weight | Curve |
|---------------------|--------------|---------------|---------------|-------------------|-------|---------|-------------------------|---------|--------|-------|
|                     | 2BALL Sleeve | (VDC)         | (mA)          | (WATTS)           | (RPM) | (CFM)   | (inch-H <sub>2</sub> O) | (dB(A)) | (g)    |       |
| EF40101BX-10000-A99 | ☉            | 12            | 122           | 1.47              | 9000  | 10.0    | 0.27                    | 33.7    | 15.8   | 1     |
| EF40101B1-10000-A99 | ☉            | 12            | 82            | 0.99              | 7000  | 8.0     | 0.19                    | 27.3    | 15.8   | 2     |
| EF40101B2-10000-A99 | ☉            | 12            | 37            | 0.45              | 5000  | 5.5     | 0.10                    | 17.7    | 15.8   | 3     |

■ Function R Type : F99 / F Type : G99

■ Air Flow-Static Pressure Characteristics

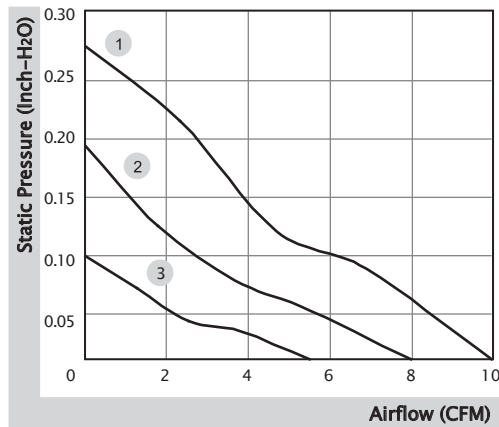

■ External Dimensions(mm)

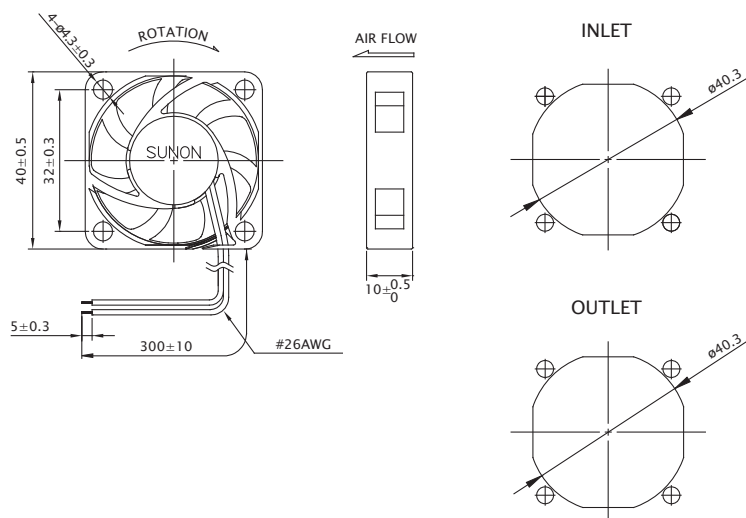

\* All model could be customized. Please contact with Sunon Sales.

\* Specifications are subject to change without notice. Please Visit SUNON website at [www.sunon.com](http://www.sunon.com) for update information.

■ RD / FG Output Signal

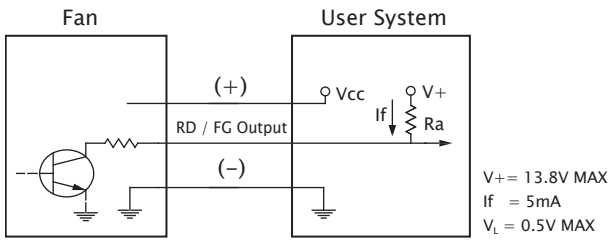

[ RD Signal ]

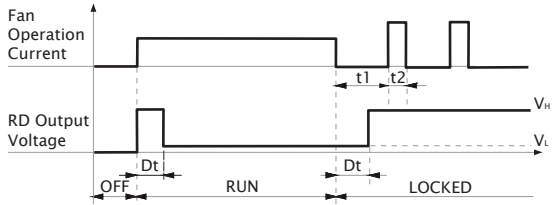

[ FG Signal ]

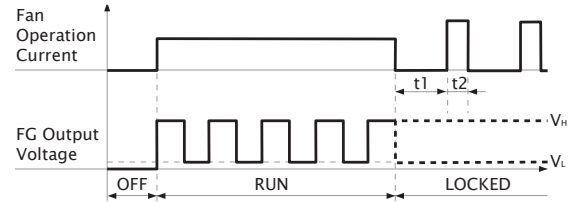
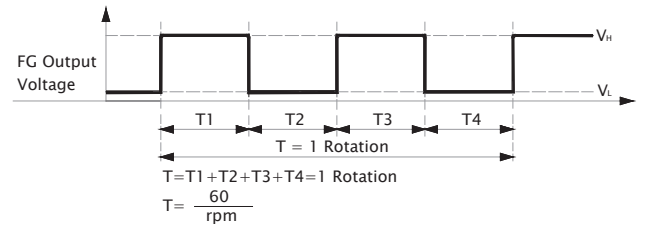

# 40x40x10 mm

7.1~8.2 CFM



■ Specification

| Model               | Bearing      | Rated Voltage | Power Current | Power Consumption | Speed | Airflow | Static Pressure         | Noise   | Weight | Curve |
|---------------------|--------------|---------------|---------------|-------------------|-------|---------|-------------------------|---------|--------|-------|
|                     | 2BALL Sleeve | (VDC)         | (mA)          | (WATTS)           | (RPM) | (CFM)   | (inch-H <sub>2</sub> O) | (dB(A)) | (g)    |       |
| EE40100S1-10000-999 | ○            | 5             | 172           | 0.86              | 7300  | 8.2     | 0.19                    | 28.2    | 15.6   | 1     |
| EE40100S2-10000-999 | ○            | 5             | 120           | 0.60              | 6100  | 7.1     | 0.12                    | 23.0    | 15.6   | 2     |
| EE40101S1-10000-999 | ○            | 12            | 82            | 0.99              | 7300  | 8.2     | 0.19                    | 28.2    | 15.6   | 1     |
| EE40101S2-10000-999 | ○            | 12            | 68            | 0.82              | 6100  | 7.1     | 0.12                    | 23.0    | 15.6   | 2     |

■ Function F Type : C99

■ Air Flow-Static Pressure Characteristics

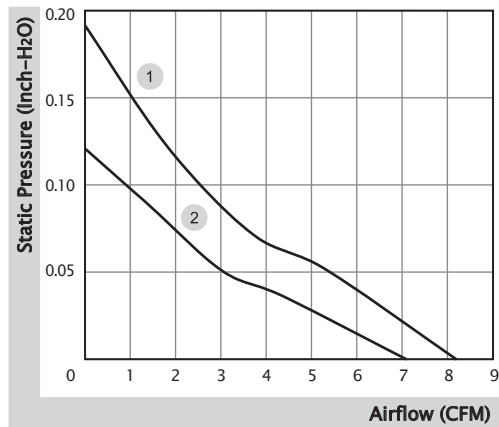

■ External Dimensions(mm)

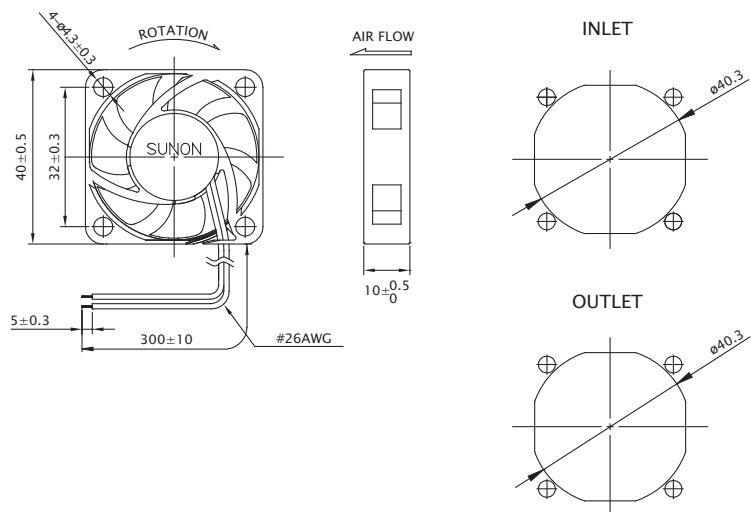

※ All model could be customized. Please contact with Sunon Sales.

※ Specifications are subject to change without notice. Please Visit SUNON website at [www.sunon.com](http://www.sunon.com) for update information.

■ RD / FG Output Signal

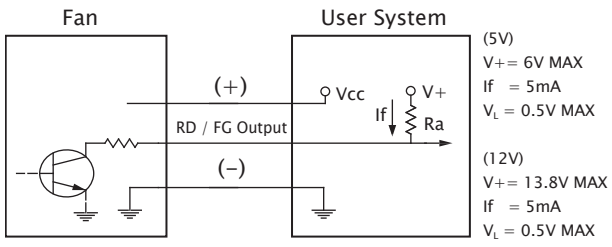

[ FG Signal ]

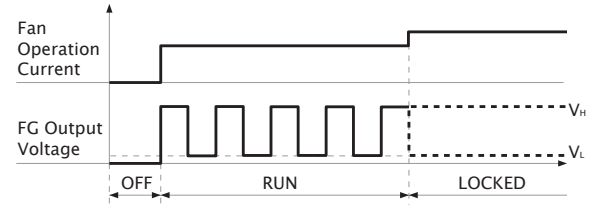
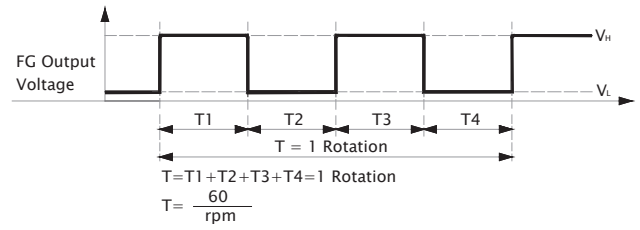

# 40x40x10 mm

5.4 CFM



■ Specification

|  | Bearing | Rated Voltage | Power Current | Power Consumption | Speed | Airflow | Static Pressure         | Noise   | Weight | Curve |
|---|---------|---------------|---------------|-------------------|-------|---------|-------------------------|---------|--------|-------|
|   | ● VAPO  | (VDC)         | (mA)          | (WATTS)           | (RPM) | (CFM)   | (inch-H <sub>2</sub> O) | (dB(A)) | (g)    |       |
| HA40101V4-10000-A99   | ●       | 12            | 31            | 0.38              | 5000  | 5.4     | 0.09                    | 15.7    | 15.4   | 1     |

■ Function F Type : G99

■ Air Flow-Static Pressure Characteristics

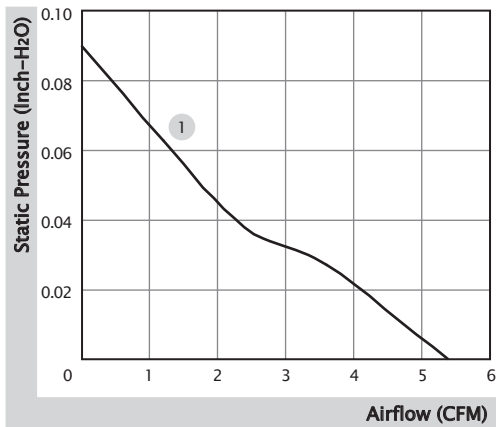

■ External Dimensions(mm)

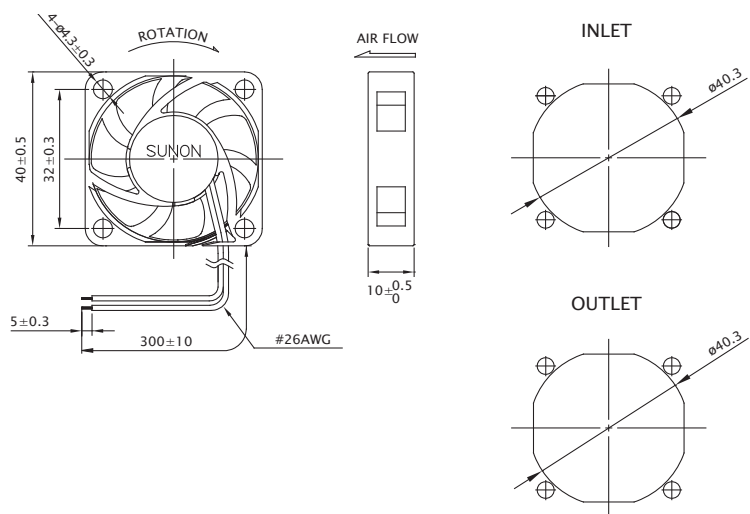

※ All model could be customized. Please contact with Sunon Sales.

※ Specifications are subject to change without notice. Please Visit SUNON website at [www.sunon.com](http://www.sunon.com) for update information.

■ RD / FG Output Signal

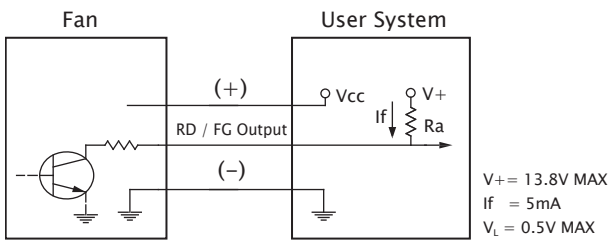

[ FG Signal ]

