

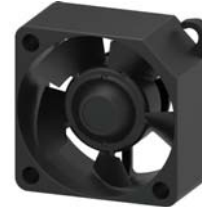

30x30x15 mm

2.7~6.0 CFM



■ Specification

	Bearing	Rated Voltage	Power Current	Power Consumption	Speed	Airflow	Static Pressure	Noise	Weight	Curve
	● VAPO	(VDC)	(mA)	(WATTS)	(RPM)	(CFM)	(inch-H ₂ O)	(dB(A))	(g)	
MF30150V1-10000-A99	●	5	140	0.70	9500	6.0	0.17	27.0	9.7	1
MF30150V2-10000-A99	●	5	80	0.40	7300	4.9	0.12	20.0	9.7	2
MF30150V3-10000-A99	●	5	45	0.23	5200	2.8	0.05	9.8	9.7	3
MF30151V1-10000-A99	●	12	65	0.78	9500	6.0	0.17	27.0	9.7	1
MF30151V2-10000-A99	●	12	35	0.42	7000	4.8	0.12	19.0	9.7	2
MF30151V3-10000-A99	●	12	20	0.24	4600	2.7	0.05	7.8	9.7	3

■ Function R Type : F99 / F Type : G99 / PWM : H99, Q99, S99

■ Air Flow-Static Pressure Characteristics

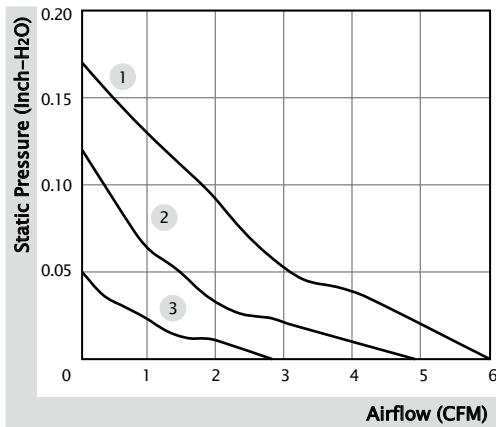

■ External dimensions(mm)

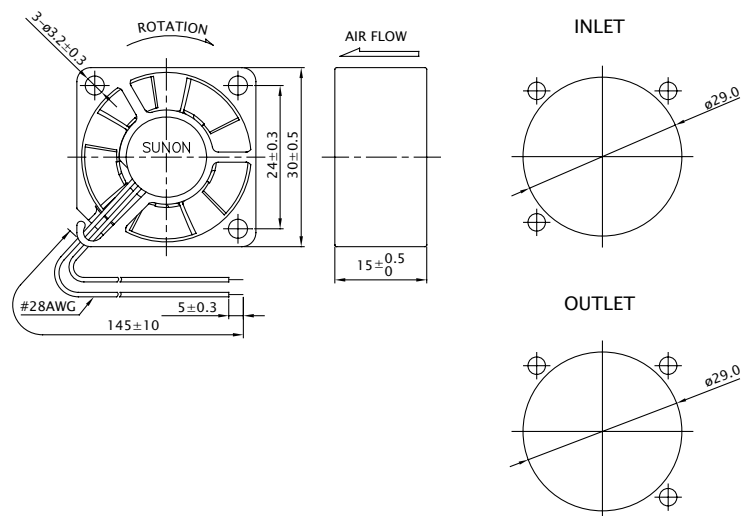

※ All model could be customized. Please contact with Sunon Sales.

※ Specifications are subject to change without notice. Please Visit SUNON website at www.sunon.com for update information.

■ RD / FG Output Signal

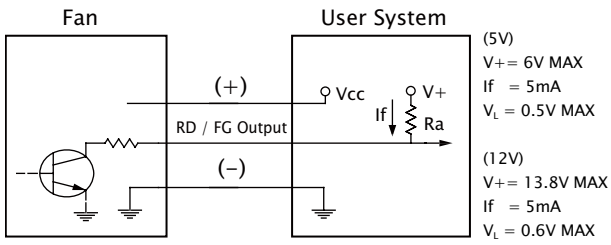

[RD Signal]

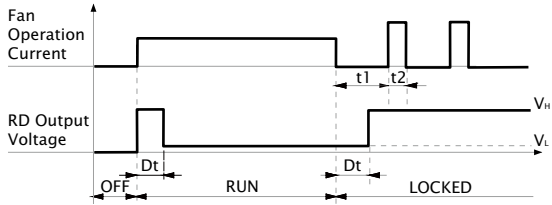

[FG Signal]

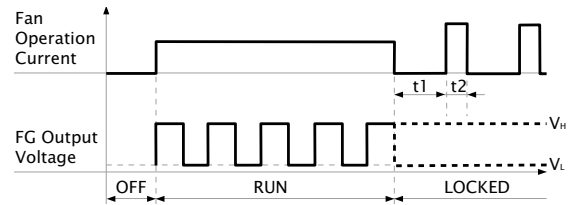
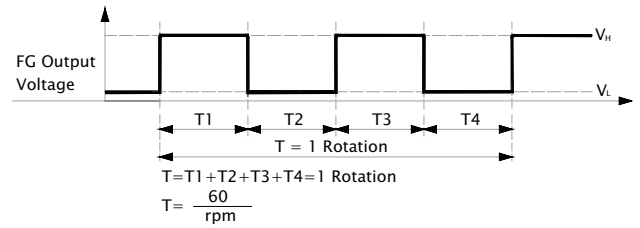

■ PWM Input Signal

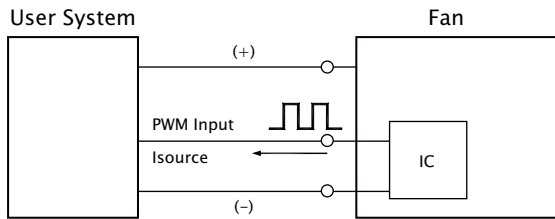

PWM FREQUENCY: 25KHZ
 Isource=0.6mA at PWM Input Voltage 0V
 The speed is default to be maximum if PWM input pin is unconnected.
 Min. start up duty cycle is 20%.

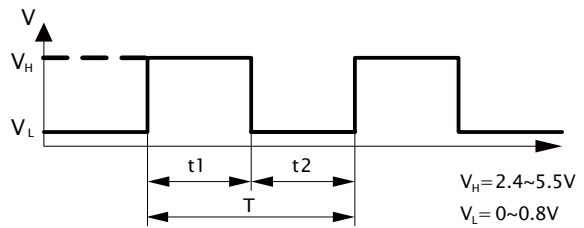

1. Period : $T = \frac{1}{f_{PWM}} = T1 + T2(\text{sec})$
2. Duty Cycle (D.C.) : $\frac{t1}{t1+t2} \times 100 = \frac{t1}{T} \times 100(\%)$

■ PWM Curve

