

展開圖

ITEM	PART	DESCRIPTION	QTY
①	12CM 3 In One ABS Plastic Filter(BB-5)RETAINER	125×125×10mm	1
②	12CM 3 In One ABS Plastic Filter(BB-5)GUARD	120.6×120.6×5.5mm	1
③	12CM Polyurethane foam	120×120×2.7mm	1

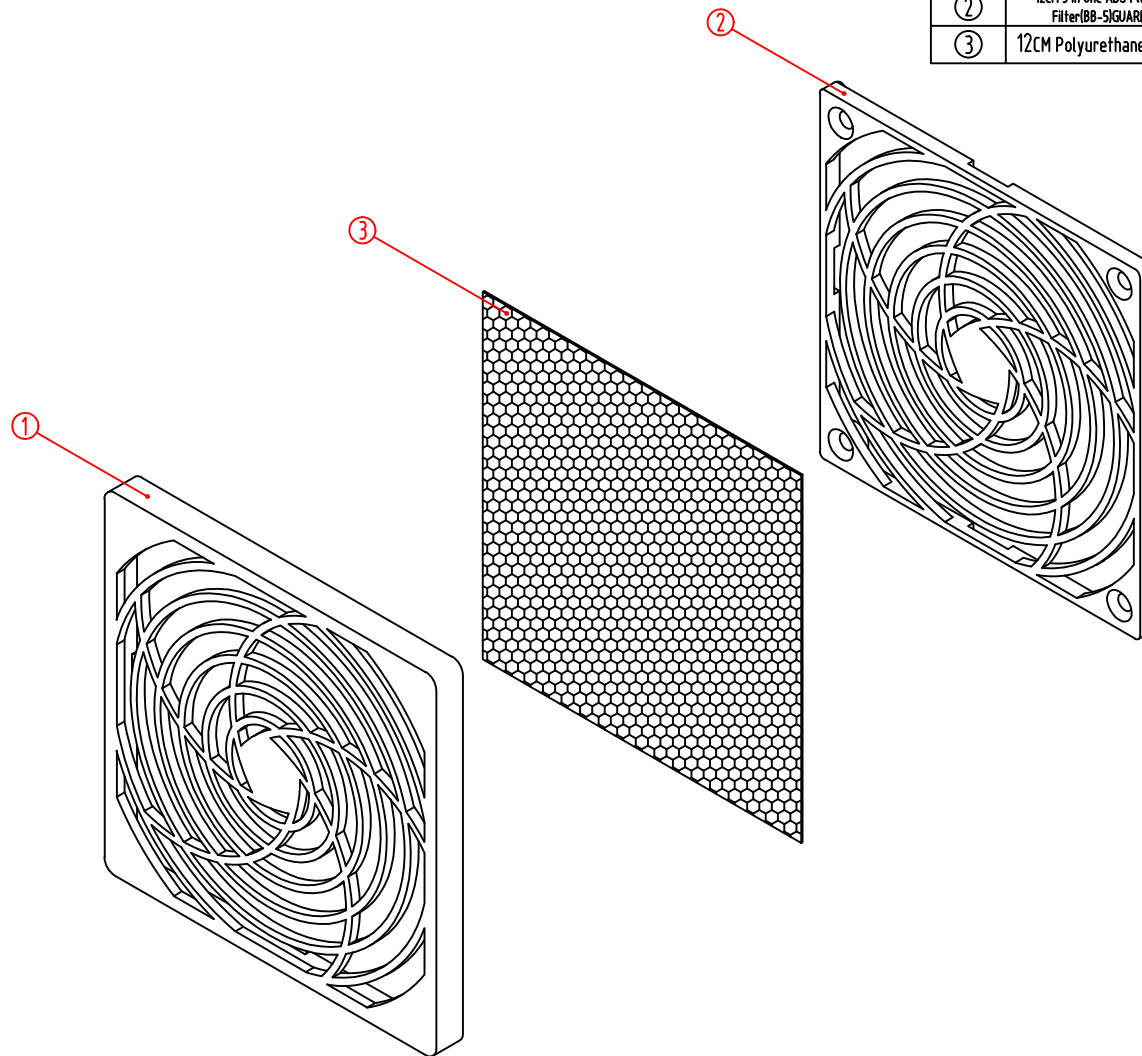

ISO9001

INVNI TECH DEVELOPING CORP.
 NO.7,ALLEY 11,LANE 144,SEC.2,YEN-PING
 NORTH ROAD,TAIPEI 103, TAIWAN R.O.C.
 TEL:(02)2553-2001 FAX:(02)2553-2004
<http://www.invnitech.com>

DRAWING	Ryu 2016.09.18	MODEL	12CM 3 In One ABS Plastic Filter(BB-5)			REV 2
CHECK	----	PART NO.	----			----
APPROVED	----	SCALE	A4 1:2	UNIT	mm	
SYMBOL	REDACTOR	DATE	DESCRIPTION			
	----	----	----			
	----	----	----			
	----	----	----			

零件圖

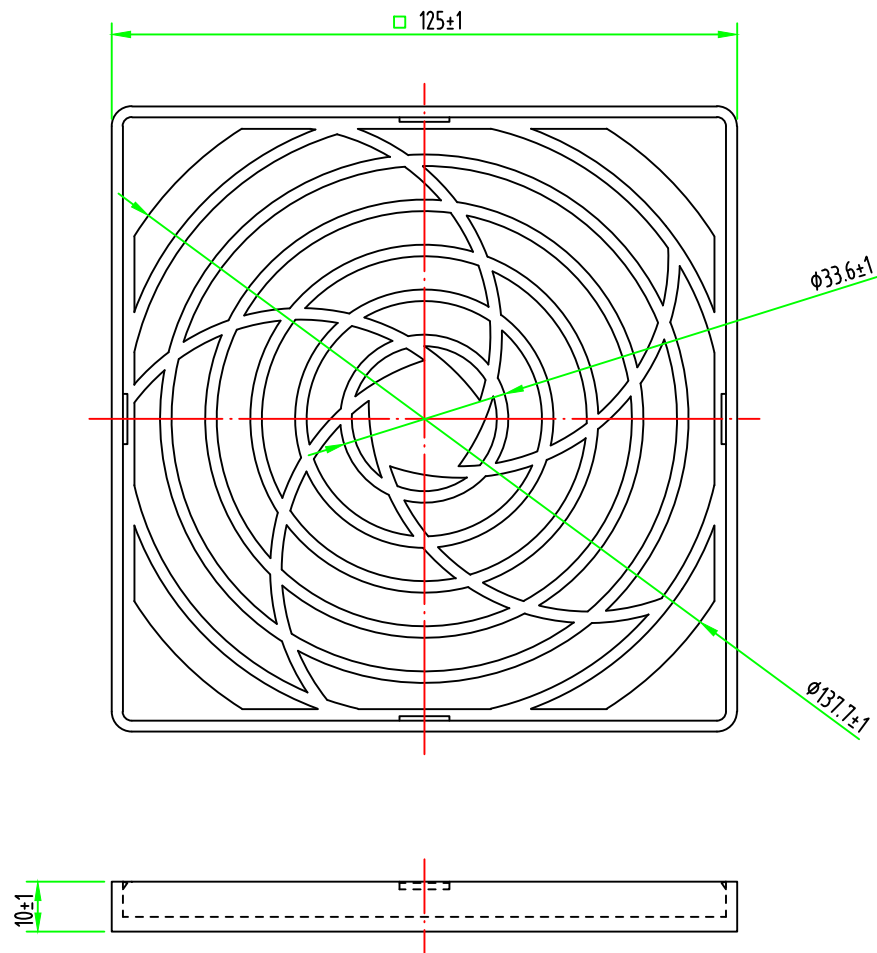
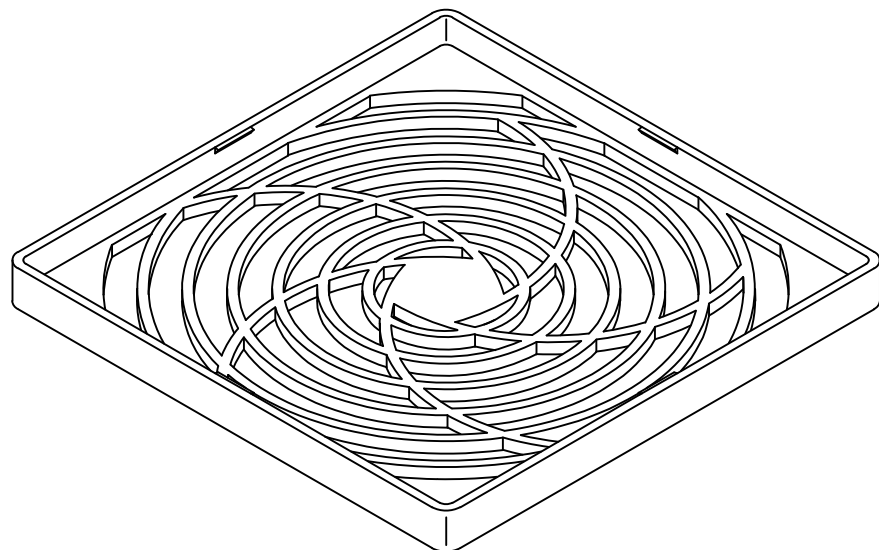

NOTE

- 1.MATERIAL: PLASTIC
- 2.PROCESSING METHODS: Plastic injection
- 3.COLOR: BLACK
- 4.FINISH: X



ISO9001

INVNI TECH DEVELOPING CORP.
 NO.7,ALLEY 11,LANE 144,SEC.2,YEN-PING
 NORTH ROAD,TAIPEI 103, TAIWAN R.O.C.
 TEL:(02)2553-2001 FAX:(02)2553-2004
<http://www.invnitech.com>

DRAWING	Ryu 2016.09.18	MODEL	12CM 3 in One ABS Plastic Filter(BB-5)RETAINER			REV 2
CHECK	----	PART NO.	----			----
APPROVED	----	SCALE	A4 1:1.5	UNIT	mm	
SYMBOL	REDACTOR	DATE	DESCRIPTION			
	----	----	----			
	----	----	----			
	----	----	----			

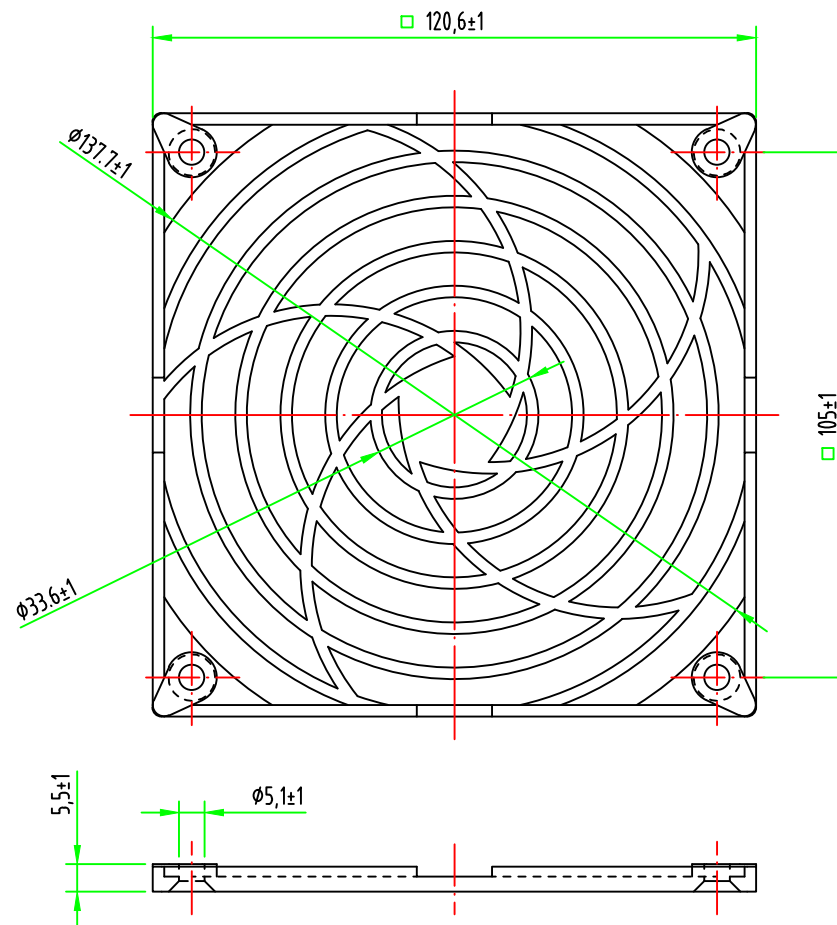
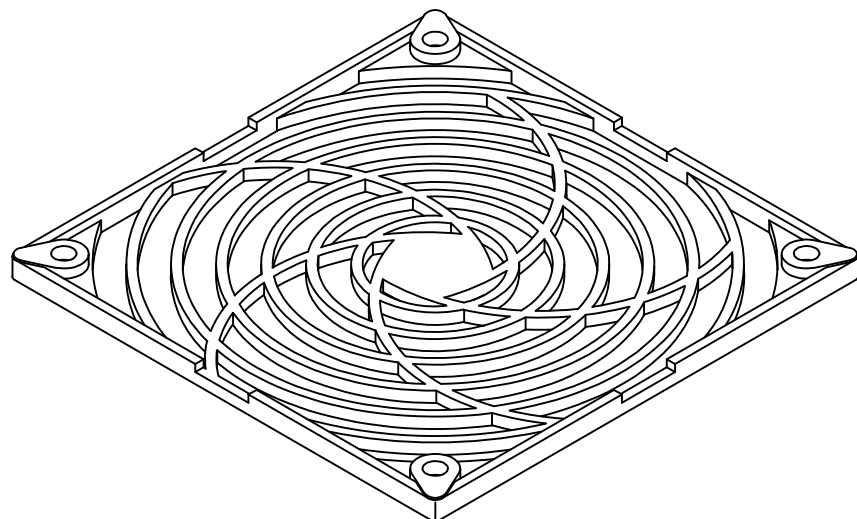

NOTE

- 1.MATERIAL: PLASTIC
- 2.PROCESSING METHODS: Plastic injection
- 3.COLOR: BLACK
- 4.FINISH: X



ISO9001

INVNI TECH DEVELOPING CORP.
 NO.7,ALLEY 11,LANE 144,SEC.2,YEN-PING
 NORTH ROAD,TAIPEI 103, TAIWAN R.O.C.
 TEL:(02)2553-2001 FAX:(02)2553-2004
<http://www.invnitech.com>

DRAWING	Ryu 2016.09.18	MODEL	12CM 3 In One ABS Plastic Filter(BB-SIGUARD)			REV 2
CHECK	----	PART NO.	----			----
APPROVED	----	SCALE	A4 1:1.5	UNIT	mm	
SYMBOL	REDACTOR	DATE	DESCRIPTION			
	----	----	----			
	----	----	----			
	----	----	----			

零件圖

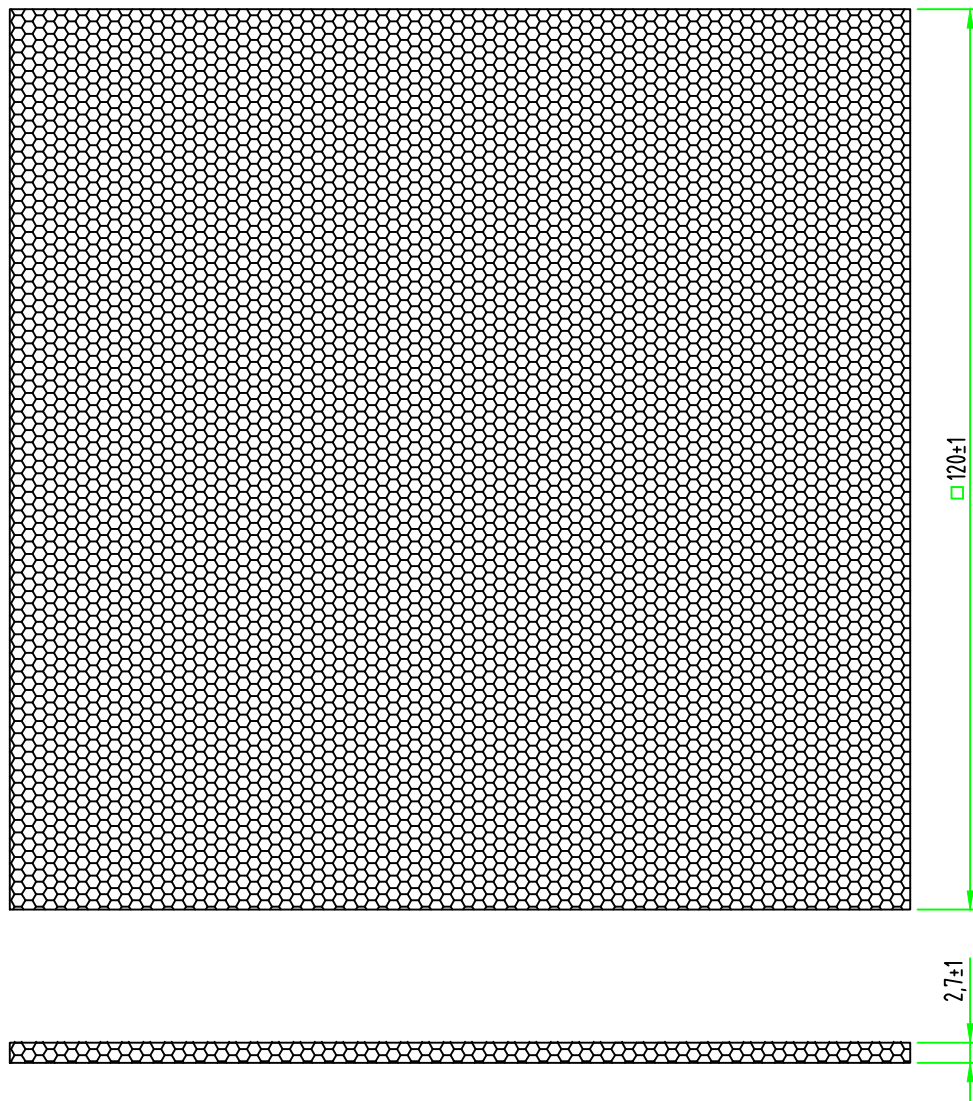

NOTE

- 1.MATERIAL: Polyurethane foam
- 2.PROCESSING METHODS: X
- 3.COLOR: BLACK
- 4.FINISH: X



INVNI TECH DEVELOPING CORP.
 NO.7,ALLEY 11,LANE 144,SEC.2,YEN-PING
 NORTH ROAD,TAIPEI 103, TAIWAN R.O.C.
 TEL:(02)2553-2001 FAX:(02)2553-2004
<http://www.invnitech.com>

DRAWING	Ryu 2016.09.18	MODEL	12CM Polyurethane foam			REV 2
CHECK	----	PART NO.	----			----
APPROVED	----	SCALE	A4 1:1	UNIT	mm	
SYMBOL	REDACTOR	DATE	DESCRIPTION			
	----	----	----			
	----	----	----			
	----	----	----			